

Assessment of a New Anemometry System for the Met Office's Moored Buoy Network

JON TURTON AND CHARLIE PETHICA*

Met Office, Exeter, United Kingdom

(Manuscript received 8 April 2010, in final form 9 August 2010)

ABSTRACT

Since the late 1980s the Met Office has operated a network of Marine Automatic Weather Stations (MAWS) around the United Kingdom. The network includes a number of instrumented moored buoys, which are mainly in exposed open-ocean locations. The anemometry is usually the first component to degrade or fail, often after 6–9 months at sea. Because the buoys are normally serviced on an annual basis, there is a need for a more durable wind system. This paper presents results from the initial deployments of a new anemometry system based on the Gill WindSonic on some of the Met Office's moored buoys, where the new wind system has been deployed alongside a conventional cup-and-vane system for comparison. The results suggest that the new wind system has shown no evidence of deterioration in its measurement accuracy, even after 8–11 months at sea. However, there is evidence of degradation in the quality of the wind data from the collocated cup-and-vane system. As a result, the new wind system will be deployed across the network to improve wind measurement reliability.

1. Introduction

Since the late 1980s the Met Office has operated a network of Marine Automatic Weather Stations (MAWS) around the United Kingdom. Observations from the network, particularly from the west of the British Isles, provide early warnings of severe weather conditions. The network includes a number of instrumented moored buoys, which are mainly in open-ocean locations on the edge of the northwest European continental shelf, with two systems in inshore waters (Fig. 1). The two most southerly buoys (Brittany and Gascogne) are operated jointly with Météo-France. Similar buoys are currently also used in the Irish buoy network. The buoys are designed to survive and operate in the northeast Atlantic, where wind speeds and waves can exceed 40 kt and 15 m (significant wave height; see Turton and Fenna 2008). The buoys are normally deployed for 2 years, with a routine annual sensor change and mooring inspection.

Each system measures air pressure, air and sea temperature, humidity, wind speed and direction, significant

wave height, and average wave period. For maximum resilience the buoys have dual suites of sensors (apart from the wave sensor) that are cross linked to dual-data acquisition and dual-transmission systems. All stations transmit their observations hourly; 24 hours a day, 365 days a year. The data from all of these systems are used by forecasters to monitor developing weather conditions and are also assimilated into numerical weather prediction (NWP) models (Ingleby 2010). Moored buoys are generally regarded as providing the highest-quality observations of a wide range of marine meteorological variables, and the data are used to provide information on the climatology of oceanic areas, “ground truth” reference data for satellite calibration/validation, and estimates of surface fluxes (e.g., Bourras 2006) for which wind speed is an essential parameter.

The anemometry is usually the first component to fail, often after 6–9 months at sea. Hence, the likelihood of either the deterioration of anemometer accuracy or its complete failure prior to the annual service means there is a need for a more reliable wind system. This is particularly important because the moored buoys are regarded as providing high-quality observations for a wide range of applications, as noted above. Also, because moored buoy networks are expensive to maintain, a wind system capable of maintaining its accuracy without needing annual replacement would be beneficial in that it would allow an extended servicing interval with a subsequent reduction

* Current affiliation: School of Geography, University of Southampton, Southampton, United Kingdom.

Corresponding author address: Jon Turton, FitzRoy Rd., Met Office, Exeter, Devon EX1 3PB, United Kingdom.
E-mail: jon.turton@metoffice.gov.uk

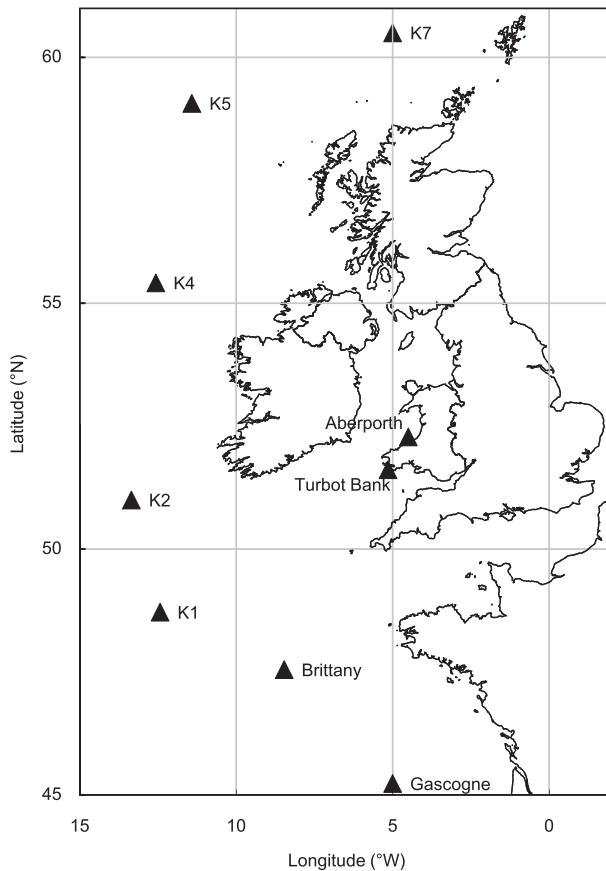

FIG. 1. Operating locations for the moored buoys in the Met Office's MAWS network.

in operating costs (e.g., ship time). Having no moving parts, a sonic anemometer was believed to provide the optimum solution, and the Gill WindSonic was chosen (in 2006) on the basis of its specification and low power consumption.

Some initial tests of the Gill WindSonic have been made by the Pacific Marine Environmental Laboratory (P. Freitag 2006, personal communication) on the Tropical Atmosphere Ocean (TAO) buoys and in the Kuroshio Extension, where the systems have operated for 6–12 months. Howden et al. (2008) have reported the reliability of the WindSonic on a U.S. National Data Buoy Center (NDBC) buoy in high winds (hurricane conditions) compared to an R. M. Young propeller anemometer, which failed at winds of about 20 m s^{-1} , and they noted that conventional anemometers can be vulnerable to mechanical failure at wind speeds above 60 mph (26.8 m s^{-1}). However, although the Gill WindSonic anemometer is becoming more widely used in the marine environment (on ships as well as buoys) few, if any, systematic evaluations of its performance have been reported.

2. The moored buoy anemometry system

For wind measurements, the system that has been used for many years is a Vector Instruments (VI) A100R cup anemometer with a VI SRW1G wind vane (marine version). To maximize the operating lifetime the VI anemometers are stripped down and rebuilt before their deployments. This includes changes to the oil used and added sealing to slow the ingress of water. This does introduce some variability into the VI systems, but the benefit is an increased lifetime. However, during operation saltwater permeates the seals and eventually the instruments fail when salt crystals form in the lubricant, leading to mechanical failure of the moving parts. Wind tunnel tests have shown that the oil changes that are made to increase durability lead to the anemometers reading slightly slow, and so a “correction” of $+1.8 \text{ kt}$ is applied in the data acquisition system processing.

A new wind system based on the WindSonic has been developed for use on the Met Office's moored buoys. Because the buoys are not fixed and can rotate in the water, the WindSonic can only measure wind direction relative to its orientation. To give true wind direction a True North Revolution compass is used to measure the orientation of the buoy. The WindSonic and compass are housed in a single sensor assembly as shown in Fig. 2, which aligns the two, so that “north” on the WindSonic on the top of the post is aligned to the “north” of the compass board housed in the junction box at the base of the post; hence, the orientation of the assembly on the buoy sensor ring is not an issue.

The (digital) outputs from the WindSonic and the Revolution compass are combined by an interface board (designed and built by Martech Systems) that provides an analog signal as output that is the same as the VI system presently used on the moored buoys. This approach was taken because the existing buoy data acquisition system is not able to accept digital inputs. This is an interim solution because, in due course, it is expected to replace the electronics with new systems that are able to accept a wider range of both digital and analog inputs.

The moored buoys are equipped with two suites of sensors. For the assessment buoys were deployed with one WindSonic–Revolution wind system (WR) alongside a standard VI system to compare results from the new wind system against the existing wind system. This is particularly important for climate application of the data, where the impact of the new system on the time series of wind data needs to be assessed. Current World Meteorological Organization (WMO) guidelines (WMO 2008) for the measurement of wind speed and direction state that an accuracy for horizontal speed of 0.5 m s^{-1} ($\sim 1 \text{ kt}$) below 5 m s^{-1} and better than 10% above

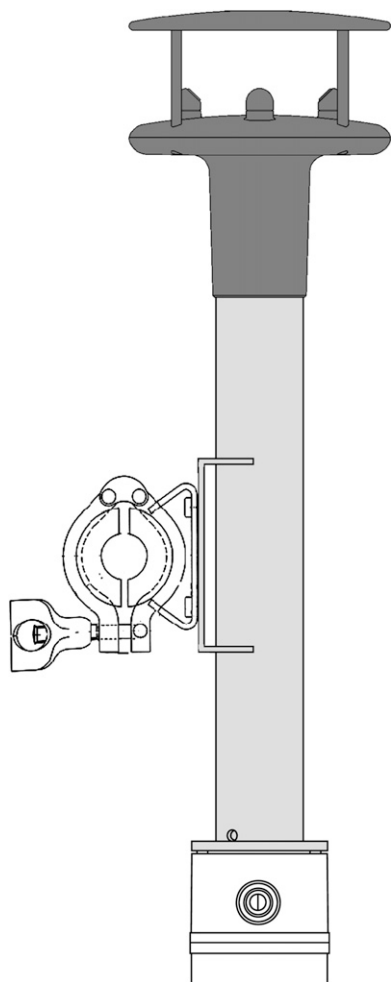

FIG. 2. Wind system assembly with (top) a Gill WindSonic and (bottom) the Revolution compass in the box. The system fits to the sensor ring using a quick-release clamp.

5 m s^{-1} speed is usually sufficient, and wind direction should be reported to the nearest 10° with an accuracy of 5° . The manufacturers' quoted accuracies for the instruments are detailed in Table 1. Note that for the WR system there will be additional directional error resulting from the use of the Revolution compass to measure the buoy orientation; the heading accuracy of the compass is quoted as 0.5° or better.

Relatively little research has been carried out to quantify the effect of buoy motion on measured wind speed and direction, so the extent to which the instruments will be affected by this is unknown. While difficult to quantify, it is believed that the effects of buoy tilt on the measurement of wind speed should be fairly small for tilts of less than 20° (Pond 1968). At higher tilts it is likely that the VI anemometer would underread the horizontal wind speed, and for the WindSonic the plate above the transducers

TABLE 1. Manufacturers quoted accuracies for the Gill WindSonic and Vector Instruments wind systems.

	Gill WindSonic	Vector Instruments
Wind speed	$\pm 2\%$ at 12 m s^{-1}	0.1 m s^{-1} from 0.7 to 10 m s^{-1} 1% between 10 and 55 m s^{-1}
Wind direction	$\pm 3^\circ$ at 12 m s^{-1}	$\pm 5^\circ$ at over 0.75 m s^{-1}

could modify the wind flow through the instrument. No measurements of tilt were made on the buoys and so measurements from both anemometer types could be affected to some extent. Wave effects (sheltering) on wind speed may also be significant at higher wind speeds. These wave effects have been shown to produce lower measured wind speeds from anemometers at 3–5-m height (Large et al. 1995).

3. Sonic anemometer deployments

Table 2 details the periods for which sonic anemometers were deployed on the buoys. The first system was deployed at sea on the K7 buoy. Although this system had operated reliably from a shore-side location for many months, it had not been previously operated at sea. Unfortunately the K7 buoy developed communications problems after a month and the data return became very intermittent. A replacement buoy was deployed at K7 in July 2008; this was a system with dual-VI systems because an already prepared system was used. During this same servicing trip a new buoy with a WR wind system was deployed at K5. Subsequently, the WR system was also deployed on replacement buoys at Brittany and Gascogne in September 2008. The buoy deployed at Brittany was the recovered K7 buoy with replacement sensors; however, it again developed intermittent communications after around 3 months and was subsequently replaced, this has since been attributed to a wiring problem. Both the Brittany and Gascogne buoys were recovered in late May 2009, although on Brittany it was discovered that the WindSonic had broken off its mounting and was missing.

TABLE 2. Moored buoy WindSonic system deployments (as at end May 2009).

Buoy	WindSonic deployed	
	From	To
K7	24 Apr 2008	19 Jul 2008
K5	19 Jul 2008	Operating
Brittany	27 Sep 2008	Data very intermittent after 28 Dec 2008, replaced at the end of May 2009
Gascogne	28 Sep 2008	Replaced at the end of May 2009

TABLE 3. Mean and RMS differences in wind speed and direction between the WR and VI systems installed on K7.

Period	Speed difference (kt)		Direction difference (°)	
	Mean	RMS	Mean	RMS
	(WR – VI)		(WR – VI)	
From 24 Apr to the end of May 2008	–1.35	1.48	–0.3	7.1
From Jun to 19 Jul 2008	–1.34	1.44	1.31	6.7

4. Results

The results from the anemometer comparisons are given in Tables 3–6 in terms of basic statistics. In all of the cases the wind speeds and directions compared are 10-min averages. Because the buoys have dual-transmission systems the measurements were transmitted hourly (in MAWS format messages) via both Meteosat and Iridium. Where both communications systems were working, then both (normally identical) wind data reports were included in the analysis. For the comparisons, the data used were extracted from these messages (as transmitted from the buoys) and were not subjected to quality control in the reprocessing. Hence, occasional data outliers, which are clearly erroneous, were seen, and in many cases they were due to communications or processing errors. The obvious erroneous outliers have been removed from the statistics presented below. Also, at some times it is clear that the VI anemometer had become “stuck,” giving a constant value of 1.8 kt; these periods have also been excluded from the statistics.

Table 3 shows that on K7 the speeds from the WR system tended to be lower than those from the VI system for the duration of the deployment. Because the buoy had been standing on the quayside for many months

TABLE 4. Mean and RMS differences in wind speed and direction between the WR and VI systems installed on K5.

Month (2008/09)	Speed difference (kt)		Direction difference (°)	
	Mean	RMS	Mean	RMS
	(WR – VI)		(WR – VI)	
July	0.03	0.51	1.7	6.3
August	–0.26	0.83	3.4	7.7
September	–0.56	0.99	4.1	7.3
October	0.04	1.00	3.3	7.4
November	–0.05	0.90	1.5	8.5
December	–0.37	0.92	4.3	8.2
January	–0.16	1.12	5.5	9.6
February	–0.28	0.92	3.1	7.0
March	–0.53	1.18	3.3	6.3
April	–0.79	1.08	7.3	9.7
May	–0.65	1.14	6.0	9.4

TABLE 5. Mean and RMS differences in wind speed and direction between the WR and VI systems installed on Brittany.

Month (2008/09)	Speed difference (kt)		Direction difference (°)	
	Mean	RMS	Mean	RMS
	(WR – VI)		(WR – VI)	
October	–0.50	0.73	3.3	6.6
November	0.21	0.71	2.6	6.6
December	0.39	0.71	1.8	5.8

before deployment, it is possible there may have been some deterioration of one (or both) of the instruments prior to deployment. However, the wind direction measurements did not differ significantly.

Table 4 shows the results from K5 for 11 months to the end of May 2009. In December 2008, January 2009, and March 2009 there were periods where the VI anemometer was clearly sticking, as shown in Fig. 3, although on each occasion it subsequently recovered. As noted earlier these stuck periods were removed from the statistics given in Table 4. Also, there was a period of near-calm winds (0300–0600 UTC 15 April 2009) where directions from at least one of the instruments were dubious, so this period has also been omitted from the statistics. Other than these occasions the agreement between the different systems was generally good. Overall there is very little bias in the wind speed measurements (the VI system reading is higher but by less than 1 kt), with a RMS difference less than 1.2 kt. For the wind direction data there is a consistent behavior in that the WR winds tend to be slightly veered compared to the VI system. Closer inspection of the data shows that the WR winds were slightly backed compared to the VI system when winds were from the northerly sector, but veered when the winds were from the south. However, this behavior was not seen in the direction data from the other buoys.

For the Brittany buoy very few data were received after 28 December because of communications system problems, so the statistics are only given for October–December

TABLE 6. Mean and RMS differences in wind speed and direction between the WR and VI systems installed on Gascogne.

Month (2008/09)	Speed difference (kt)		Direction difference (°)	
	Mean	RMS	Mean	RMS
	(WR – VI)		(WR – VI)	
October	–0.36	0.54	–5.7	7.4
November	–0.30	0.94	–5.9	6.7
December	–0.05	0.54	–6.3	7.1
January	0.15	0.61	–5.9	6.6
February	–0.03	0.49	–7.5	8.0
March	–0.34	0.47	–6.8	7.5
April	–0.55	0.66	–5.8	6.7
May	–0.74	0.88	–6.0	8.6

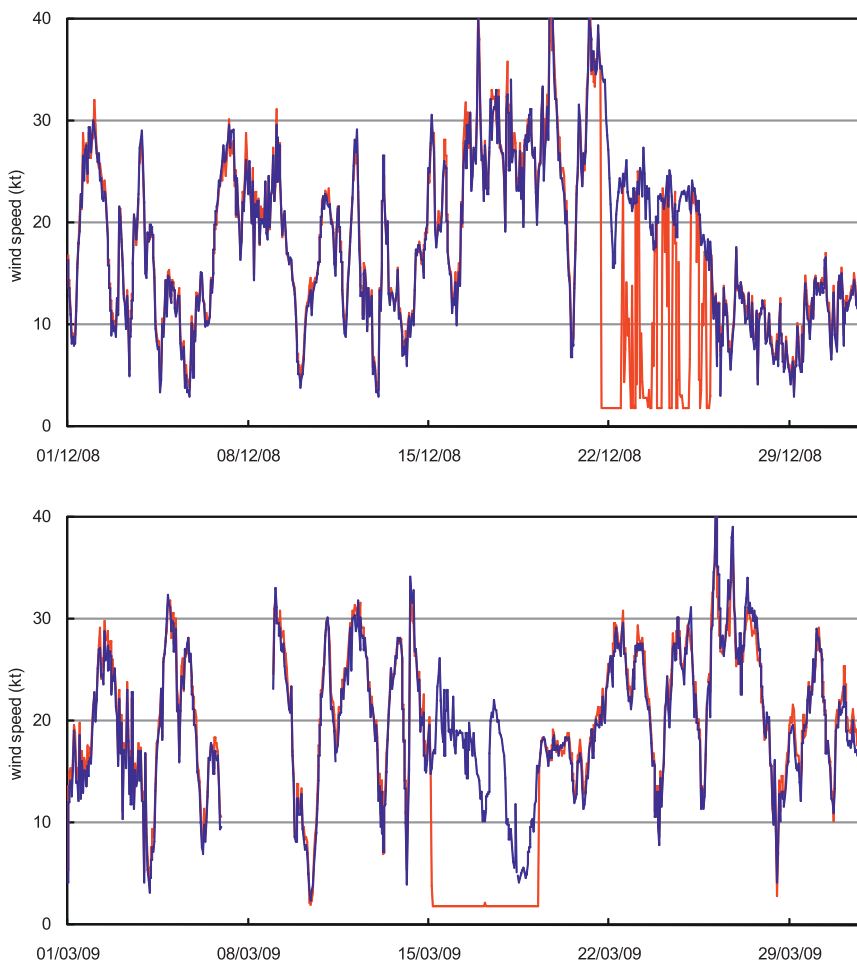

FIG. 3. Time series of wind speed from K5 during December 2008 and March 2009 showing periods where the VI anemometer had clearly stuck. (top) December 2008 and (bottom) March 2009 with WindSonic (blue) and VI (red).

(Table 5). These show that to end October 2008 the WR speeds tended to be slightly lower than those from the VI system, but in November and December they were slightly higher. In both November and December there was an indication that at lower wind speeds the WR system gave higher readings; this may be a result of increased friction in the VI anemometer leading it to underread in lower wind speeds. For wind direction there is a tendency for the WR directions to be slightly veered of the VI directions.

At around the same time as the Brittany buoy was replaced the Gascogne buoy was also deployed. Table 6 shows that the wind speeds between the two instruments gave good agreement throughout the deployment, suggesting there was minimal deterioration in the instruments. Overall, the WR wind speeds were slightly lower than the VI anemometer and the WR wind directions tend to be slightly backed from the VI wind vane measurements over the period.

a. Postdeployment WindSonic calibration

At the end of May 2009 the Brittany and Gascogne buoys were replaced. The WindSonic that had been deployed on Gascogne was subsequently tested in a wind tunnel at 12 m s^{-1} (23 kt) and 32 m s^{-1} (62 kt) to examine how well it had maintained its accuracy following 8 months at sea. It was not possible to check the Brittany WindSonic because it had broken off and been lost. Because the WindSonic has some directional sensitivity (resulting from the effect of the posts on the measurement), particularly at higher wind speeds, it was rotated throughout 360° and the measurements recorded every 2° . The results are summarized in Table 7.

While there are some differences pre- and postdeployment, for wind speed the difference in accuracy of the WindSonic pre- and postdeployment is negligible at 12 m s^{-1} and very small at 32 m s^{-1} , in each case being significantly less than the accuracy requirements for the

TABLE 7. Mean and standard deviation of the wind speed during the pre- and postdeployment calibrations for the Gascogne WindSonic.

Calibration	Tunnel wind speed (m s^{-1})	Wind speed		Wind direction difference	
		Mean	Std dev	Mean	Std dev
Predeployment	12	11.99	0.04	-1.18	0.71
	32	31.95	0.42	-1.00	0.88
Postdeployment	12	11.99	0.06	-0.88	0.84
	32	32.12	0.59	-0.90	0.94

instrument. For wind direction, no significant differences are seen between the pre- and postdeployment calibration, where in both cases the WindSonic average error was around 1° . Hence, the results show no indications that the accuracy of the instrument had deteriorated during its 8-month deployment at sea.

In the wind tunnel tests at the higher wind speed of 32 m s^{-1} there was some directional dependence in the wind speed measurements, with the smallest measurement errors corresponding to when the upwind posts on the instrument were perpendicular to the wind direction (i.e., the instrument's north, east, south, and west). For the wind direction there was a sinusoidal-like modulation in the directional error at both 12 and 32 m s^{-1} with four cycles during the 360° rotation, where the errors were close to the mean for the instrument's north, east, south, and west. However, it is likely, with the motion (rotation) of the buoy at sea and the 10-min averaging applied, that the overall RMS errors would be representative of the measurements made.

b. Comparison of dual VI systems on the K7 replacement

Following the communications problems on the initial deployment of K7 a replacement buoy carrying twin VI systems was deployed in July 2008. The differences between the measurements from these "identical" VI systems are summarized in Table 8 to provide a reference for the comparisons presented earlier.

The two VI systems agreed well (RMS difference of ~ 0.5 kt) for wind speed during August and September when speeds were generally low (with average speeds of 11 – 12 kt). In October and November winds were higher and the agreement less good (with an RMS difference > 0.9 kt). From December to April the wind speeds agreed less well with RMS differences of 1.4 – 2.5 kt and anemometer 1 consistently read higher than anemometer 2, apart from a period in mid-December (the 8th–20th) when it read significantly lower by (typically) 2 – 3 kt.

Independent monitoring by the European Centre for Medium-Range Weather Forecasts (ECMWF; J.-R. Bidlot 2009, personal communication) has indicated that the K7

TABLE 8. Mean (anemometer 1 – anemometer 2) and RMS differences in wind speed and direction between the two VI systems installed on K7.

Month (2008/09)	Speed difference (kt)		Direction difference ($^\circ$)	
	Mean	RMS	Mean	RMS
August	0.17	0.49	-0.7	5.6
September	0.19	0.55	-0.3	6.1
October	-0.08	0.92	-1.7	5.1
November	0.20	0.99	-1.2	5.0
December	-0.68	2.19	-1.1	6.5
January	1.12	1.46	0.0	5.0
February	2.34	2.42	-1.1	4.3
March	2.19	2.38	-0.7	5.2
April	2.33	2.55	-0.1	4.7
May	-0.48	1.82	-1.0	6.0

wind speed observations reported on the WMO Global Telecommunications System (based on anemometer 1) developed a negative bias with respect to their NWP model from the end of April. Met Office monitoring also shows that the bias (observation – model) increased from -1.0 kt in April to -2.7 kt in May, suggesting that anemometer 1 was increasingly underreading. Hence, the information available is consistent with anemometer 2 starting to slow from January 2009 and anemometer 1 starting to slow from the end of April, so that in May it was likely that both anemometers on K7 were underreading, with anemometer 1 showing signs of sticking at low wind speeds in late April and late May.

Direction measurements were generally in good agreement between the two instruments and showed no signs of deterioration over time.

These results show evidence of the VI anemometers on K7 both slowing down after different periods of time such that the wind speed measurements from dual-VI cup-and-vane anemometers can diverge, where one (or both) systems can be in error. Where such degradation is gradual it can be difficult to identify which system(s) is faulty. However, it should be recognized that K7 is in a particularly exposed location to the north of Scotland and often subject to severe weather conditions, so it is perhaps the most stringent test of the anemometry.

c. Instrument differences with increasing wind speed

To better compare the differences between the two wind systems, the RMS wind speed and direction measurement differences were calculated over different ranges of wind speed. Only data for the first 3 months of deployment of each buoy were used to ensure using VI anemometer data of the best quality. Differences in the measurements between the two systems were averaged over 5 -kt bands of speed as measured by the VI system and

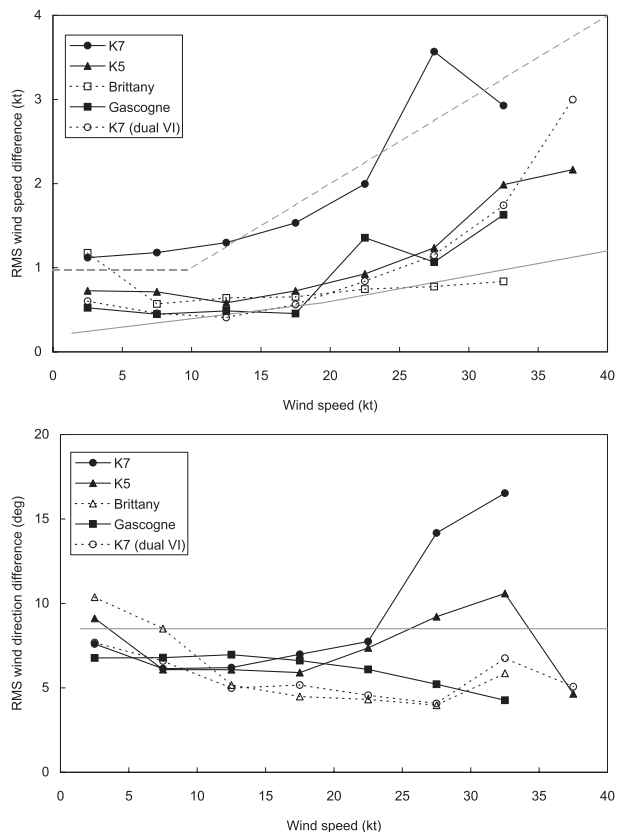

FIG. 4. RMS differences for (top) wind speed and (bottom) wind direction between the two instruments on each buoy averaged over 5-kt intervals referenced to the VI system. The differences that would arise if both instruments satisfied the quoted accuracies of the instruments are indicated (solid gray lines; see Table 1). The WMO guideline accuracy for wind speed (dashed gray line) is also shown.

are shown in Fig. 4. For wind speed it can be seen that the poorest agreement was for the initial K7 deployment. As noted earlier, this buoy had been on the quayside for months prior to deployment and it is possible that the accuracy from one (or both) of the anemometers may have degraded. Nevertheless, the wind speed differences are still within 2 times the WMO guideline accuracy. For all the other systems, the wind speeds agree fairly well over the range of measurements (apart from Brittany, at speeds up to 5 kt) and are within 1 times the WMO guideline accuracy. The wind speed differences between the two VI systems on the K7 replacement (dual-VI systems) are not significantly different to those on the buoys with WR systems. As expected, the RMS difference in speed tends to increase with wind speed and is generally greater than would be expected if both systems met their quoted accuracies.

For wind direction all of the systems show similar RMS differences up to 25 kt, with K7 (initial deployment) showing the largest differences at higher wind speeds.

However, apart from K7 at the higher wind speeds, the agreement is generally better than 10° (2 times the WMO guideline).

5. Conclusions

Results from the comparisons show that the differences in wind speed and direction between the WR and VI systems are generally small; but are greater than would be expected from the instrument specifications, although for the most part are within the WMO guideline accuracy. Wind speed errors tend to increase with wind speed, whereas the wind direction errors tend to decrease with wind speed for speeds up to 10 kt. However, the differences between the WR and VI systems are not significantly different to those measured when using two “identical” VI systems on the same buoy (the K7 replacement).

The results suggest that the WR wind system generally gives good agreement with the existing VI system. The results also show that the wind speeds from the VI system can degrade with time, but there is no evidence of the winds from the WR system deteriorating with time. Being an acoustic–electronic-based system, it should be more durable because it is not susceptible to bearing failures and slowdown as the VI system is. It is also seen that the nature of the differences between the WR wind system and the VI system do vary from buoy to buoy; this is in part due to variability in the individual VI and WR systems. Even though the WindSonic is a solid-state instrument, wind tunnel tests (not reported here) have shown variability in the measurements between instruments, and hence individual calibration of each WindSonic before deployment is recommended to minimize errors in measurements.

An important conclusion is that for extended deployments, the wind speed data from the VI cup anemometers should not be regarded as being of climate quality because of the gradual degradation–failure of the system. This was seen on the K7 replacement where there was evidence of deterioration in the accuracy of the VI anemometers.

Postdeployment calibration of the WindSonic recovered from the Gascogne buoy shows no evidence of deterioration in its measurement accuracy, even after 8 months at sea. Hence, even though the initial accuracy of the WindSonic may be less than the VI system, it is expected that it should retain its accuracy for longer after deployment and in doing so provide more consistent wind speed measurements.

In summary, the results suggest that the new WR wind system works sufficiently well to continue its rollout across the Met Office’s moored buoy network, and it is planned

that from 2010 dual-WR systems will be deployed across the network to improve wind measurement reliability. However, it is recommended that wind tunnel calibration of the WindSonic anemometers be carried out both before installation on and after recovery from each buoy.

Acknowledgments. We would like to acknowledge the efforts of the Met Office's marine engineering team in maintaining the moored buoy network and developing the new wind system described in this paper.

REFERENCES

- Bourras, D., 2006: Comparison of five satellite-derived latent heat flux products to moored buoy data. *J. Climate*, **19**, 6291–6313.
- Howden, S., D. Gilhousen, N. Guinasso, J. Walpert, M. Sturgeon, and L. Bender, 2008: Hurricane Katrina winds measured by a buoy-mounted sonic anemometer. *J. Atmos. Oceanic Technol.*, **25**, 607–616.
- Ingleby, B., 2010: Factors affecting ship and buoy data quality: A data assimilation perspective. *J. Atmos. Oceanic Technol.*, **27**, 1476–1489.
- Large, W. G., J. Morzel, and G. B. Crawford, 1995: Accounting for surface wave distortion of the marine wind profile in low-level ocean storms wind measurements. *J. Phys. Oceanogr.*, **25**, 2959–2976.
- Pond, S., 1968: Some effects of buoy motion on measurements of wind speed and stress. *J. Geophys. Res.*, **73**, 507–512.
- Turton, J., and P. Fenna, 2008: Observations of extreme wave conditions in the north-east Atlantic during December 2007. *Weather*, **63**, 352–355.
- WMO, 2008: *Guide to Meteorological Instruments and Methods of Observation*. 7th ed. WMO, 677 pp.